LN870 Intrinsically Safe Light Tower

A multi-tier Light Tower for status indication in hazardous areas

**ATEX certified EX II2G,
EEx ia IIC T4**

**Available in five super-bright
colors**

Suitable for zones 1 and 2

11 year life expectancy

Low current

**Two tiers operable from a single
IIC power source**

Built-in vibration shock absorber

Direct or pole mounting

The LN870 Light Tower provides visual on/off indication of process conditions in safe and hazardous areas. The unit is available up to a maximum of five tiers and each tier can be selected from five super-bright colors: red, amber, white, blue and green.

Each tier has a unique prism cut lens and internal reflective cone to improve visibility and requires one LED Lamp for illumination which is current-limited to take a maximum of only 20mA. Available for hazardous area use in both zones 1 and 2, up to two tiers can be driven from a single IIC interface.

There is a choice of pole or direct mounting, both incorporating a special vibration absorber.

With the LED's low power consumption, low heat dissipation and long life expectancy, the LN870 is an ideal indicator for safe and hazardous areas alike.



Technical Specification

Tiers

Can be stacked up to five tiers high using five different colors in any order.

Colors

Each tier available in five super-bright colors. Colors are red, amber, green, blue and white.

High Reliability

All tiers illuminated with high reliability LED lamps designed to provide a minimum of 100,000 hours service life.

Low Current Consumption

All LED Lamps operate at 20mA or less and feature integral current limiting to maintain consistent brightness over the operating range of the voltage supply.

Use in Hazardous Areas

In hazardous areas the light tower LED lamps must be powered through suitable intrinsically safe isolators or barriers. Up to two LED lamps and therefore two tiers can be driven from a single IIC interface.

Mounting

A special anti-vibration absorber built into the lower portion of the moulding effectively reduces vibration to the LED Lamps.

The unit can be pole or direct base mounting.

Configuration

It is easy to change the order of the colors. Lenses simply unscrew and LED Lamps can be installed in any position.

Certification

ATEX certified to EN50014:1997 and EN50020:2002

Group II, Category 2G, EEx ia IIC T4
Ta -4°F to +140°F (Ta -20°C to +60°C)

Location

Zones 1 or 2. Gas Group, IIC, IIB or IIA, Temp Class up to T4

Certificate No.

Kema03ATEX1022X

Safety Parameters

Ui = 45V

li = 2A

Pi = 1.2W

max ambient temp. = 140°F (60°C)

Pi = 1.3W

(max ambient temp. = 104°F (40°C))

Ci = Li = 0

The device can be powered from an EEx ia IIC certified interface with output parameters lower than those shown above.

Supply

With suitable certified interface
18-35VDC, current 20mA per tier

Recommended Interfaces

Zener Barriers: S967-POS, S985-POS

IS Isolators: MTL5021 only
(IIB only), MTL7728P+

Environment

Operating temperature:

-4°F to 104°F (-20°C to 40°C) (Pi <=1.3W)

Operating temperature:

-4°F to 140°F (-20°C to 60°C) (Pi <=1.2W)

Storage temperature:

-4 to 176°F (-20 to 80°C)

Humidity: 0-95% RH, non condensing

Protection

IP40, IP54 option available

Construction

Heat and shock resistant polycarbonate

Connections

Two flying leads per lamp/tier both marked with tier number. Terminations must be rated to IP20 minimum

Mounting

Direct base or optional pole mounting, both have vibration absorbing base

Compliance

Immunity to EN61000-6-2:2001

Emissions to EN61000-6-4:2001

Weight

0.77lb (350g) for one tier and 0.11lb (50g) for each additional tier

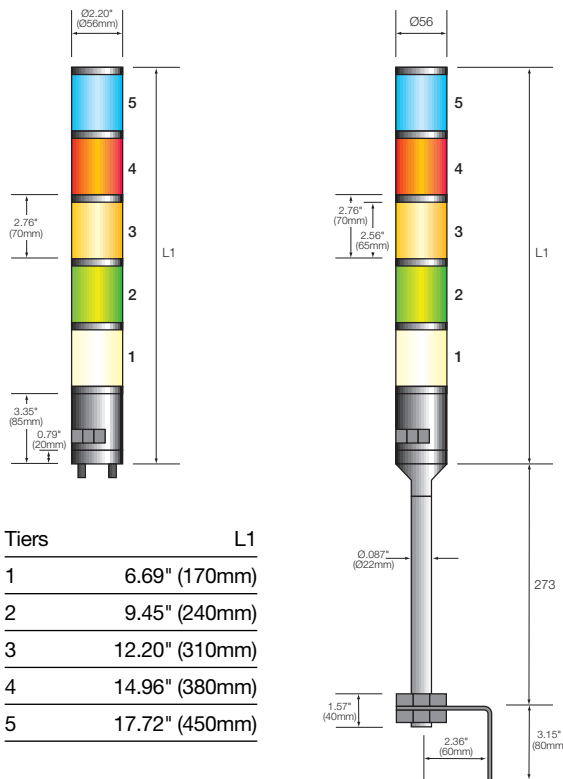

Due to our policy of continuous product development, we reserve the right to amend specifications without notice.



RTK Instruments
1531 Stuyvesant Avenue
Union
New Jersey 07083
USA

A member of the MTL Instruments Group plc

Telephone: 908 688 6709
Facsimile: 908 688 9040
Email: sales@rtkinstruments.com
Web: www.rtkinstruments.com