



Product Data Sheet

(Mini-Y-Purge) Mini-Z-Purge Control System for Leakage Compensation

For enclosures up to

1ZLC/___/___ (1YLC/___/___) 60 cu ft, 1.7 m³
2ZLC/___/___ (2YLC/___/___) 120 cu ft, 3.4 m³
3ZLC/___/___ (3YLC/___/___) 240 cu ft, 6.8 m³

"Z" Purge Zone 2 (22) Category G D3 ATEX, Class I Division 2 Grp A to D

"Y" Purge Class I Division 1 Grp A to D



MiniPurge
LC Panel Mount



MiniPurge
LC Back Plate

OPERATION

For purged enclosures in Class I Division 2 Gp A-D, Zone 2 IIC [EEx pz] optional [EEx nZ] and Zone 22 [EEx pD].

The Leakage Compensation (LC) Pressurizing system has an initial High Purge Flow rate to remove the gasses which may be present when the purged enclosure is initially closed. The high purge rate is initiated manually.

When the purge is turned off a small amount of air flow maintains the enclosure pressure. This compensates for leaks, conserving compressed air.

Typical Enclosure Size:

60 ft³ (1.7 m³) @ 8 scfm = 225 NI/min
 120 ft³ (3.4 m³) @ 16 scfm = 450 NI/min
 240 ft³ (6.8 m³) @ 32 scfm = 900 NI/min

Note: Enclosure sizes are based on 30-minute purge period. There is no restriction on this purge period.

COMPONENTS

The system has two components. The Control Unit controls air flow and monitors flow and pressure. The Relief Valve (RLV) allows the flow of purge gas and provides the measurement of the flow through the enclosure then closes at the end of purging. Preferred options are Panel Mount and Back Plate option. Panel Mount fits directly on the enclosure with minimum external space. Back Plate mounts either directly onto the outside of or remote from the enclosure.

FEATURES

- + One Model number includes the Control Unit (CU) and Relief Valve (RLV)
- + Simple integrated mounting with little or no piping needed.
- + ATEX, FM and cULus approvals cover Europe, USA and Canada.
- + Clear visual status indication.
- + Remote Alarm contacts.

COMMON SPECIFICATION

The Control Unit:-

Purge Medium:- Compressed Air or Inert Gas.

Clean, dry, free of flammable gasses.

Supply Pressure:- 60 psi (4 bar)

Maximum working pressure: 115 psi (8 bar)

Supply Pipe: Model # 1 & 2 - 1/2" (15mm) O/D, Model # 3 - 3/4" (20mm). Max. Length: 20ft (6 meters).

Temperature: -4°F, -20°C to 131°F, 55°C

Manual Purge flow On/off Lever

Relief Valve (RLV)

Magnetic operation (patented) with integral spark arrestor.
Opening pressure 4" wc, 1kPa, 10 mbar.

Purge Flow Sensor:- 8 scfm (225 NI/min), 16 scfm (450 NI/min), 32 scfm (900 NI/min). 1/4" (6mm) pipe required between Control Unit and RLV, to be installed internal to the purged enclosure.

Indicators Alarms: - "Alarm" Red Indicates Low Pressure.
Green Indicates Pressure OK

Low Pressure Sensor "Alarm": setting 0.2" wc (0.5 mbar)

"Purge Flow" Yellow indicates purge flow through the enclosure.

Permissible enclosure leakage: 2 scfm (60 NI/min)

Materials of construction

Control Unit: - 316L stainless steel mounting plate.

Relief Valve: - 316L stainless steel.

www.expoworldwide.com



ATEX



Technical Specification

Mini-Z-Purge Mini-Y-Purge

1ZLC/___/___, 2ZLC/___/___, 3ZLC/___/___

1YLC/___/___, 2YLC/___/___, 3YLC/___/___

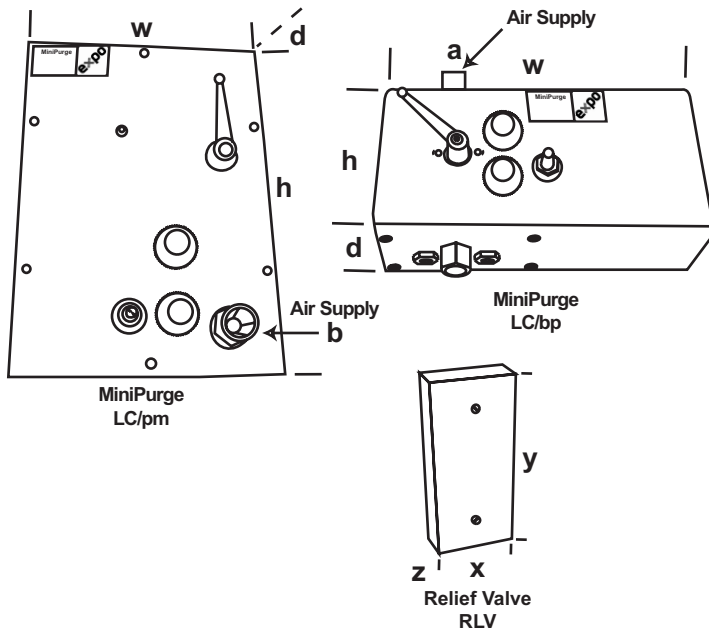

Dimensions Control Unit	_ZLC/pm/_ _YLC/pm/_		_ZLC/bp/_ _YLC/bp/_			
Width w	7.9"	200mm	10.1"	257mm		
Height h	10.9"	275mm	5.0"	127mm		
Depth d	3.9"	98mm	3.1"	78mm		
Signals	1/8" NPT(F)		1/8" NPT(F)			
Purge fit. length	1.0"	25mm	0.4"	11mm		
Purge Inlet a	1/2" NPT(F)		3/8" NPT(F)			
Dimensions Relief Valve	1ZLC/pm/ 1ZLC/bp/ RLV25		2ZLC/pm/ 2ZLC/bp/ RLV36		3ZLC/pm/ 3ZLC/bp/ RLV52	
RLV Width x	2.4"	62mm	3.5"	88mm	4.3"	110mm
RLV Height y	5.2"	133mm	6.7"	170mm	7.3"	185mm
RLV Depth z	1.3"	33mm	1.5"	38mm	1.7"	42mm
Weight	7lb	3kg	9lb	4kg	11lb	5kg

Note 'Z' Purge IS output

IS output can be connected to Intrinsically Safe or non-incendive circuits, with the panel mount PM option, it can also be connected to general purpose (GP) circuit powered from inside the enclosure.

COMMON SPECIFICATION

Control Unit:-

Location of Control unit.

Panel Mount:

Model No. 1, 2 or 3ZLC/pm/IS or /PO

Model No. 1, 2 or 3YLC/pm/IS or /PO

Control Unit Location: Side or Front of purge enclosure.

Back Plate:

Model No. 1, 2 or 3ZLC/bp/IS or /PO

Model No. 1, 2 or 3YLC/bp/IS or /PO

Control Unit Location: Top, Side or Bottom of purge enclosure.

Warning Label: (loose) for User's calibration details, for mounting to purged enclosure.

"Alarm" Remote options:-

/IS Dry contacts for switching intrinsically safe circuits

"Power" contact closed to enable power, contact open for trip disconnect. "Alarm" open on loss of pressure.

/PO "Pneumatic output"

"Alarm" output at line pressure

Pressure output No output pressure = Alarm

OPERATION

Type Number (example)

1 Z LC/bp/IS

Size

- 1 Purge flow rate 8scfm, 225 NI/min
- 2 Purge flow rate 16scfm, 450 NI/min
- 3 Purge flow rate 32scfm, 900 NI/min

Certification / Approval

- Z North America Class I Division 2
FM 1X8a4AE, cUL E190061
Europe ATEX Category G D3
EXPO 06ATEX1061X [Ex pz] [Ex pD]

Y

- North America Class I Division 1
For protecting Class I Division 2 equipment
FM 1X8a4AE, cUL E190061

Pressurization method

- LC Leakage Compensation

Housing

- bp Back Plate
- pm Panel Mount

Output see above

- IS Intrinsically safe output
- PO Pneumatic output

Expo Technologies Ltd

Summer Road, Thames Ditton,
Surrey, KT7 0RH, UK

T +44 (0) 20 8398 8011

F +44 (0) 20 8398 8014

E sales@expoworldwide.com

Expo Technologies Inc

P.O. Box 486, Chagrin Falls,
Ohio 44022-0486, USA

T 888-NFPA-496 (Toll Free)

F +1 440 247 5409

E sales.na@expoworldwide.com

www.expoworldwide.com

Expo Technologies reserve the right to amend data given here without prior notice.
©2003 Expo Technologies. Mini-Z-Purge™ is a trademark of Expo Technologies.